

FS 70-7 CI

Single Convolution Air Spring

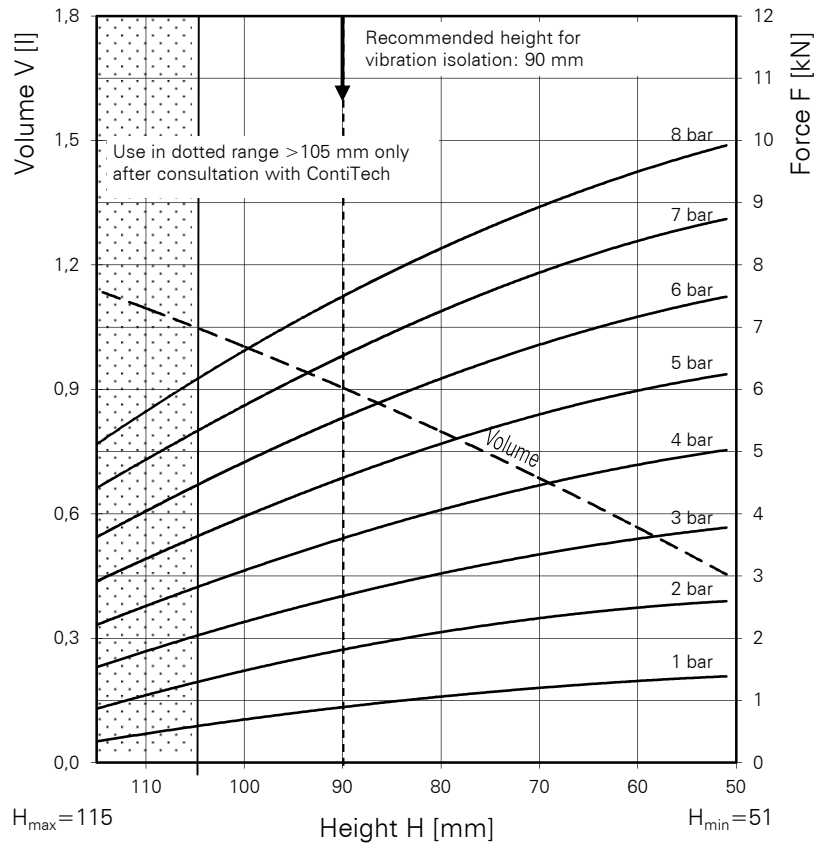
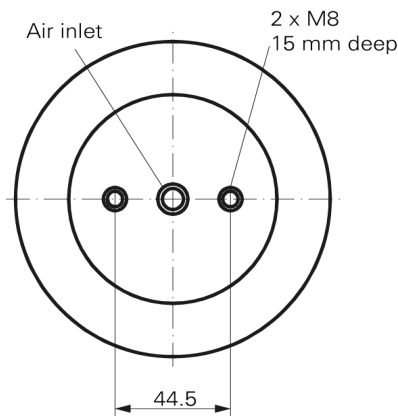
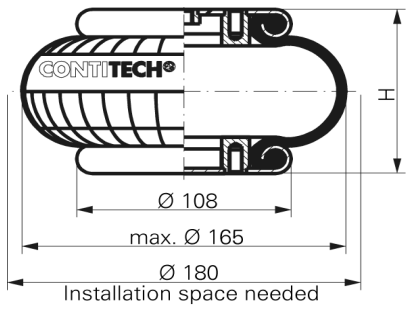

Purchase order data

Type	Order No.
Rubber bellows only	60512
With clamped plates G 1/4 air inlet	2681 015 000
With stainless steel clamped plates G 1/4 air inlet	61746

Additional types on request

Technical data

Min. pressure	0 bar
Return force to min. height	≤ 200 N
Overall weight with clamped plates	1.2 kg

Vibration isolation - dynamic characteristic values

Design height H: recommended 90mm, minimum 70mm

Pressure p [bar]	3	4	5	6	7	8	Vol V [l]	
Force (Load) [kN]	2.7	3.7	4.7	5.7	6.6	7.7		0.9
Spring rate [N/cm]	1040	1270	1530	1770	2060	2325		
Natural frequency [Hz]	3.1	2.9	2.9	2.8	2.8	2.7		

Pneumatic application - static characteristic values

Force F [kN]

Pressure p [bar]	3	4	5	6	7	8	Vol. [l]		
Height H [mm]	100	2.2	3.1	4.0	4.8	5.7		6.6	1.0
	90	2.7	3.6	4.6	5.6	6.5		7.5	0.9
	80	3.1	4.1	5.1	6.2	7.3		8.3	0.8
	70	3.4	4.5	5.6	6.7	7.9		9.0	0.7
	60	3.6	4.8	6.0	7.2	8.4		9.5	0.6



Service instructions
M 8 = 25 Nm
G 1/4 = 25 Nm

Measuring procedure: Room temperature / Force- height- data quasistatic / Dynamic data at 1 Hz